

OSRAM

Our Brand

LED ENGIN



Light is OSRAM

Amber LED Emitter

LZ4-00A108

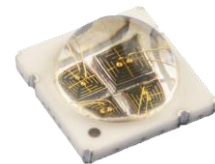

Key Features

- High Luminous Efficacy 6.3W Amber LED
- Ultra-small foot print – 7.0mm x 7.0mm
- Surface mount ceramic package with integrated glass lens
- Very low Thermal Resistance (2.8°C/W)
- Individually addressable die
- Very high Luminous Flux density
- JEDEC Level 1 for Moisture Sensitivity Level
- Autoclave compliant (JEDEC JESD22-A102-C)
- Lead (Pb) free and RoHS compliant
- Reflow solderable (up to 6 cycles)
- Emitter available on Serially Connected MCPCB (optional)

Typical Applications

- Emergency vehicle lighting
- Strobe and warning lights
- Marine and buoy lighting
- Aviation and obstruction lighting
- Roadway beacons and traffic signaling
- Architectural lighting
- Automotive signal and marker lights

LZ4-00A108

Part number options

Base part number

Part number	Description
LZ4-00A108-xxxx	LZ4 emitter
LZ4-40A108-xxxx	LZ4 emitter on 1 channel Standard Star MCPCB

Bin kit option codes

A1, Amber (590nm)

Kit number suffix	Min flux bin	Color bin range	Description
0000	R	A3 – A6	full distribution flux; full distribution wavelength

Luminous Flux Bins

Table 1:

Bin Code	Minimum	Maximum
	Luminous Flux (Φ_V) @ $I_F = 700\text{mA}$ ^[1,2] (lm)	Luminous Flux (Φ_V) @ $I_F = 700\text{mA}$ ^[1,2] (lm)
R	285	356
S	356	445
T	445	556
U	556	695

Notes for Table 1:

- Luminous flux performance guaranteed within published operating conditions. LED Engin maintains a tolerance of $\pm 10\%$ on flux measurements.
- Future products will have even higher levels of luminous flux performance. Contact LED Engin Sales for updated information.

Dominant Wavelength Bins

Table 2:

Bin Code	Minimum	Maximum
	Dominant Wavelength (λ_P) @ $I_F = 700\text{mA}$ ^[1,2] (nm)	Dominant Wavelength (λ_P) @ $I_F = 700\text{mA}$ ^[1,2] (nm)
A3	587.5	590
A4	590	592.5
A5	592.5	595
A6	595	597.5

Notes for Table 2:

- Dominant wavelength is derived from the CIE 1931 Chromaticity Diagram and represents the perceived hue.
- LED Engin maintains a tolerance of $\pm 1.0\text{nm}$ on dominant wavelength measurements.

Forward Voltage Bins

Table 3:

Bin Code	Minimum	Maximum
	Forward Voltage (V_F) @ $I_F = 700\text{mA}$ ^[1,2] (V)	Forward Voltage (V_F) @ $I_F = 700\text{mA}$ ^[1,2] (V)
0	8.96	11.60

Notes for Table 3:

- LED Engin maintains a tolerance of $\pm 0.04\text{V}$ for forward voltage measurements.
- Forward Voltage is binned with all four LED dies connected in series.

Absolute Maximum Ratings

Table 4:

Parameter	Symbol	Value	Unit
DC Forward Current ^[1]	I_F	1000	mA
Peak Pulsed Forward Current ^[2]	I_{FP}	1500	mA
Reverse Voltage	V_R	See Note 3	V
Storage Temperature	T_{stg}	-40 ~ +125	°C
Junction Temperature	T_J	125	°C
Soldering Temperature ^[4]	T_{sol}	260	°C
Allowable Reflow Cycles		6	
Autoclave Conditions ^[5]		121°C at 2 ATM, 100% RH for 168 hours	
ESD Sensitivity ^[6]		ESD Sensitive Device Class 0 ANSI/ ESDA/ JEDEC JS-001 HBM	

Notes for Table 4:

- Maximum DC forward current (per die) is determined by the overall thermal resistance and ambient temperature. Follow the curves in Figure 10 for current derating.
- Pulse forward current conditions: Pulse Width \leq 10msec and Duty Cycle \leq 10%.
- LEDs are not designed to be reverse biased.
- Solder conditions per JEDEC 020D. See Reflow Soldering Profile Figure 3.
- Autoclave Conditions per JEDEC JESD22-A102-C.
- LED Engin recommends taking reasonable precautions towards possible ESD damages and handling the LZ4-00A108 in an electrostatic protected area (EPA). An EPA may be adequately protected by ESD controls as outlined in ANSI/ESD S6.1.

Optical Characteristics @ $T_c = 25^\circ\text{C}$

Table 5:

Parameter	Symbol	Typical	Unit
Luminous Flux (@ $I_F = 700\text{mA}$) ^[1]	Φ_V	400	lm
Luminous Flux (@ $I_F = 1000\text{mA}$) ^[1]	Φ_V	520	lm
Dominant Wavelength ^[2]	λ_P	590	nm
Viewing Angle ^[3]	$2\Theta_{1/2}$	100	Degrees
Total Included Angle ^[4]	$\Theta_{0.9V}$	120	Degrees

Notes for Table 5:

- Luminous flux typical value is for all four LED dies operating concurrently at rated current.
- Amber LEDs have a significant shift in wavelength over temperature; please refer to Figure 6 for details. Caution must be exercised if designing to meet a regulated color space due to this behavior as product may shift out of legal color space under elevated temperatures.
- Viewing Angle is the off axis angle from emitter centerline where the luminous intensity is $\frac{1}{2}$ of the peak value.
- Total Included Angle is the total angle that includes 90% of the total luminous flux.

Electrical Characteristics @ T_C = 25°C

Table 6:

Parameter	Symbol	Typical	Unit
Forward Voltage (@ I _F = 700mA) ^[1]	V _F	10.0	V
Forward Voltage (@ I _F = 1000mA) ^[1]	V _F	10.4	V
Temperature Coefficient of Forward Voltage ^[1]	ΔV _F /ΔT _J	-11.2	mV/°C
Thermal Resistance, electrical (Junction to Case)	RΘ _{J-C}	2.8	°C/W

Note for Table 6:

- Forward Voltage typical value is for all four LED dies connected in series.

IPC/JEDEC Moisture Sensitivity Level

Table 7 - IPC/JEDEC J-STD-20D.1 MSL Classification:

Level	Soak Requirements					
	Floor Life		Standard		Accelerated	
	Time	Conditions	Time (hrs)	Conditions	Time (hrs)	Conditions
1	Unlimited	≤ 30°C/ 85% RH	168 +5/-0	85°C/ 85% RH	n/a	n/a

Note for Table 7:

- The standard soak time is the sum of the default value of 24 hours for the semiconductor manufacturer’s exposure time (MET) between bake and bag and the floor life of maximum time allowed out of the bag at the end user of distributor’s facility.

LZ4-00A108

Mechanical Dimensions (mm)

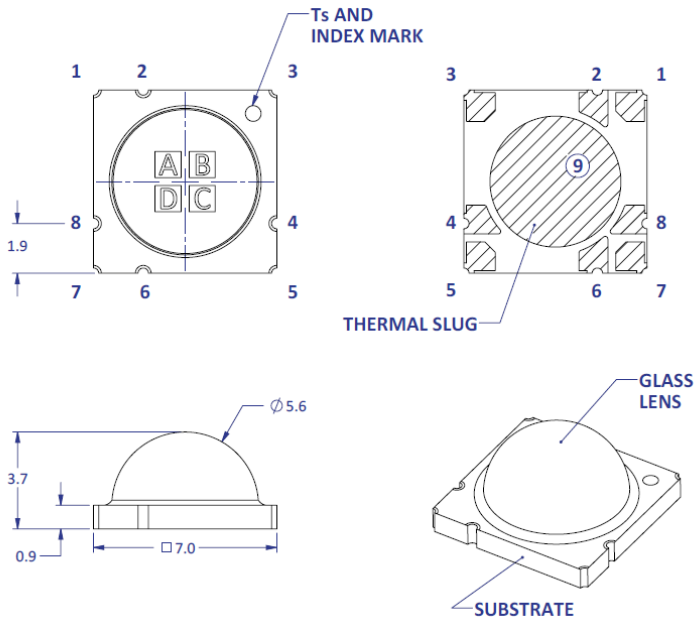

Pin Out		
Pad	Die	Function
1	A	Anode
2	A	Cathode
3	B	Anode
4	B	Cathode
5	C	Anode
6	C	Cathode
7	D	Anode
8	D	Cathode
9 [2]	n/a	Thermal

Figure 1: Package outline drawing

Notes for Figure 1:

1. Unless otherwise noted, the tolerance = ± 0.20 mm.
2. Thermal contact, Pad 9, is electrically neutral.

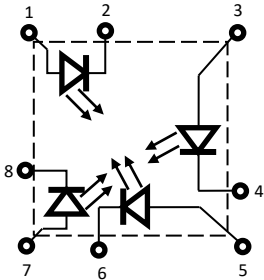

Recommended Solder Pad Layout (mm)

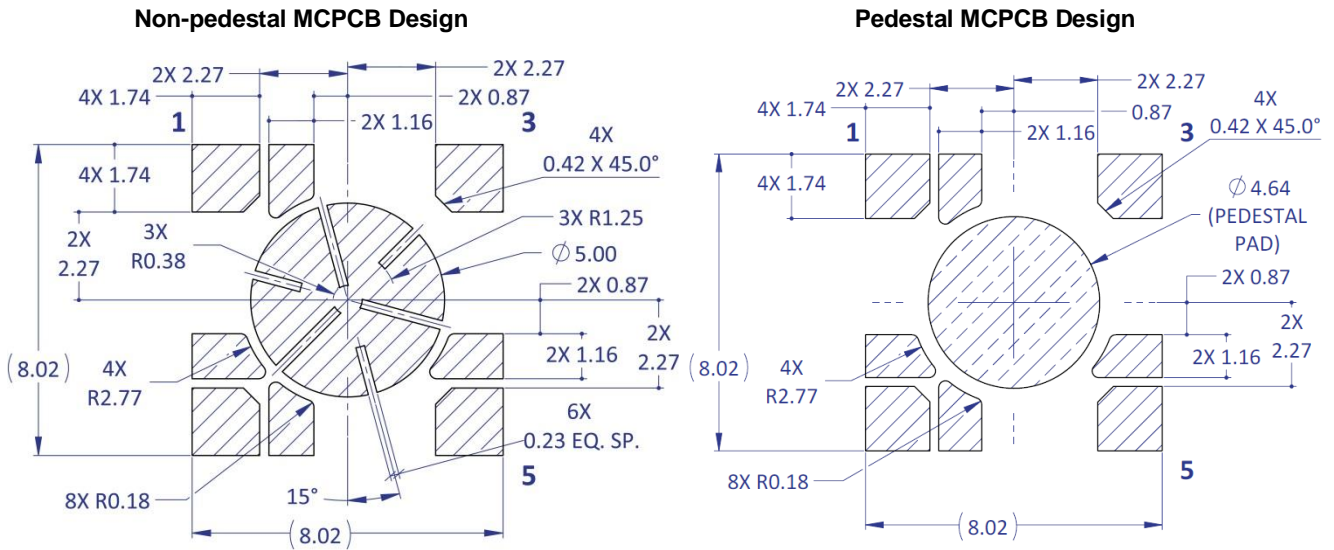

Figure 2a: Recommended solder pad layout for anode, cathode, and thermal pad for non-pedestal and pedestal design

Notes for Figure 2a:

1. Unless otherwise noted, the tolerance = ± 0.20 mm.
2. Pedestal MCPCB allows the emitter thermal slug to be soldered directly to the metal core of the MCPCB. Such MCPCB eliminate the high thermal resistance dielectric layer that standard MCPCB technologies use in between the emitter thermal slug and the metal core of the MCPCB, thus lowering the overall system thermal resistance.
3. LED Engin recommends x-ray sample monitoring for solder voids underneath the emitter thermal slug. The total area covered by solder voids should be less than 20% of the total emitter thermal slug area. Excessive solder voids will increase the emitter to MCPCB thermal resistance and may lead to higher failure rates due to thermal over stress.

Recommended Solder Mask Layout (mm)

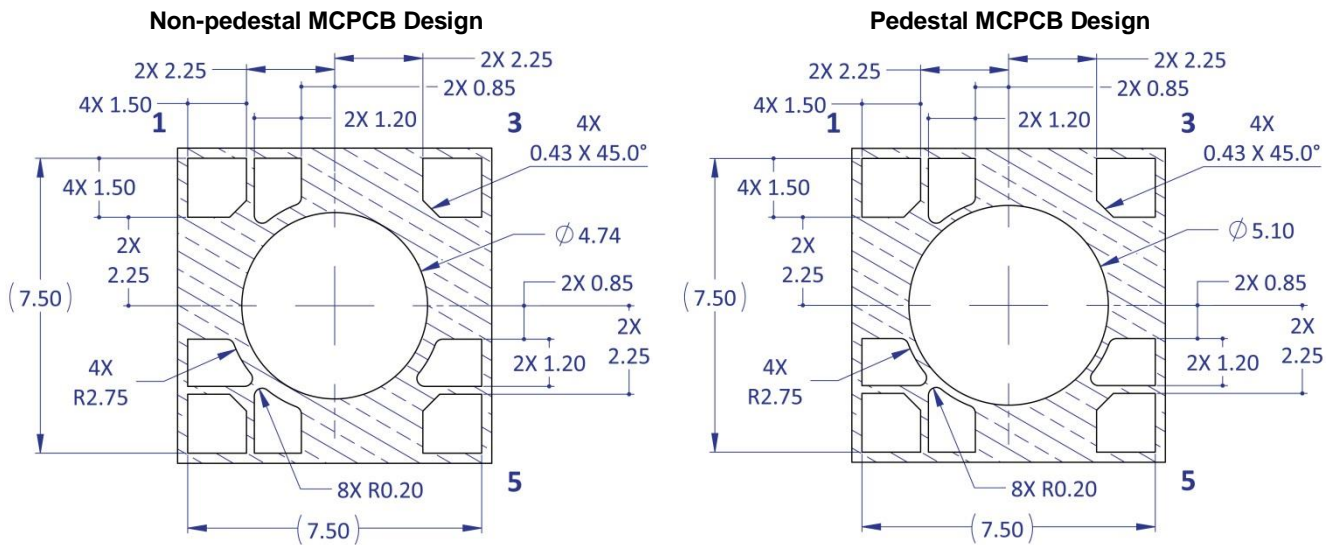

Figure 2b: Recommended solder mask opening for anode, cathode, and thermal pad for non-pedestal and pedestal design

Note for Figure 2b:

1. Unless otherwise noted, the tolerance = ± 0.20 mm.

Recommended 8mil Stencil Apertures Layout (mm)

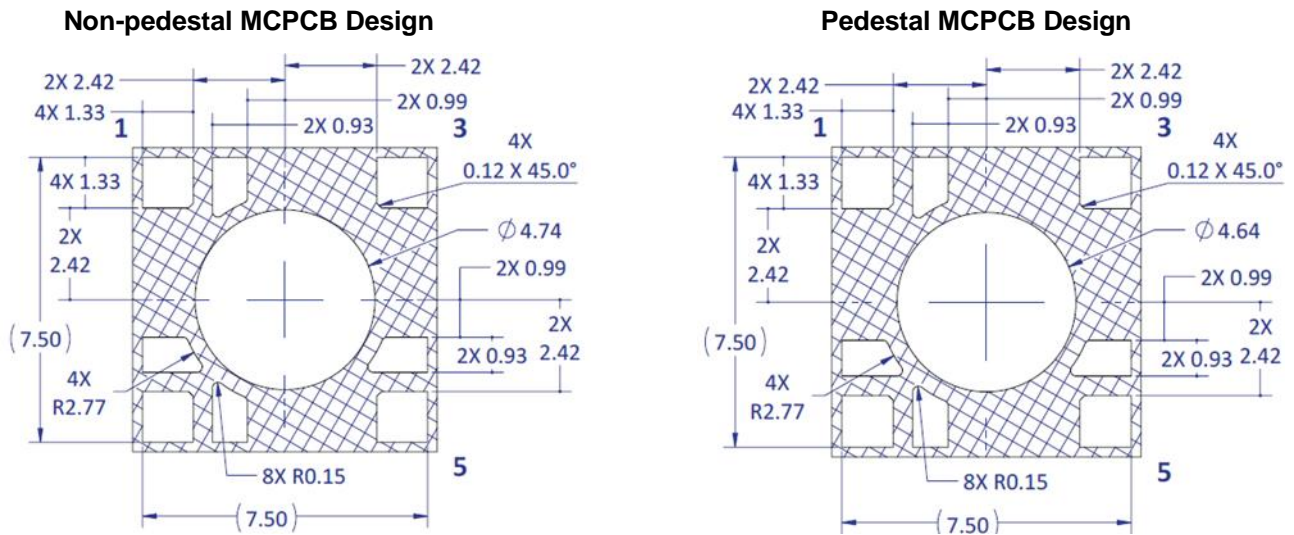

Figure 2c: Recommended 8mil stencil apertures for anode, cathode, and thermal pad for non-pedestal and pedestal design

Note for Figure 2c:

- 1. Unless otherwise noted, the tolerance = ± 0.20 mm.

Reflow Soldering Profile

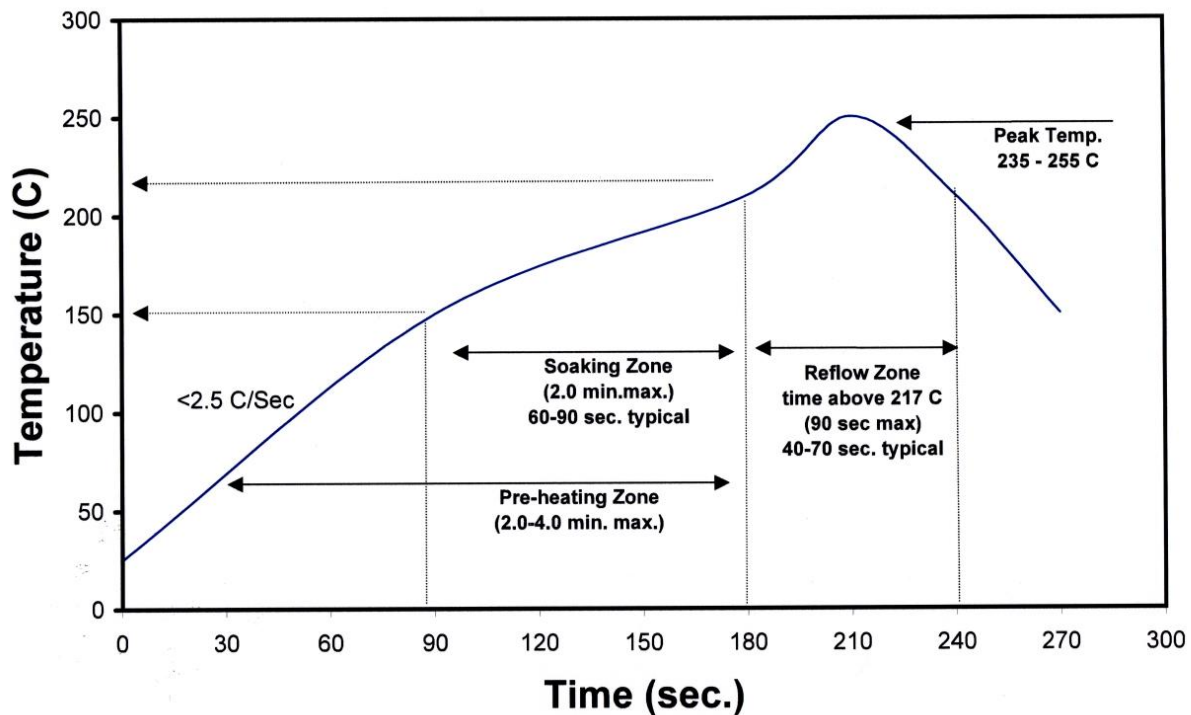

Figure 3: Reflow soldering profile for lead free soldering

Typical Radiation Pattern

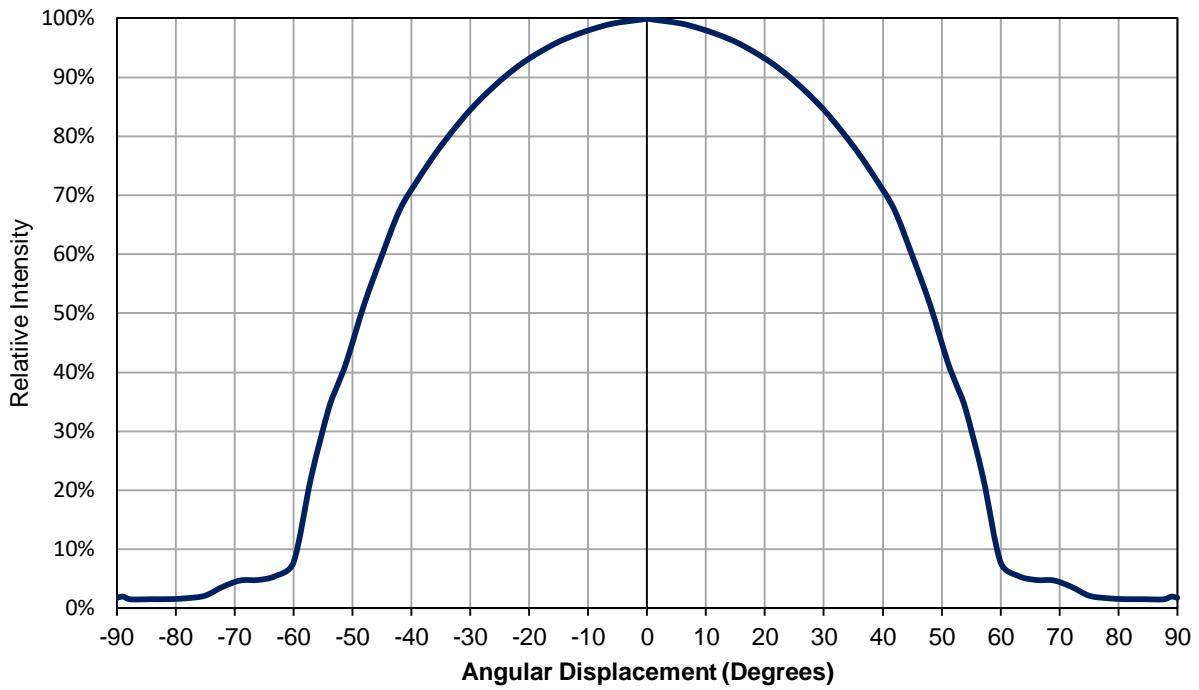

Figure 4: Typical representative spatial radiation pattern

Typical Relative Spectral Power Distribution

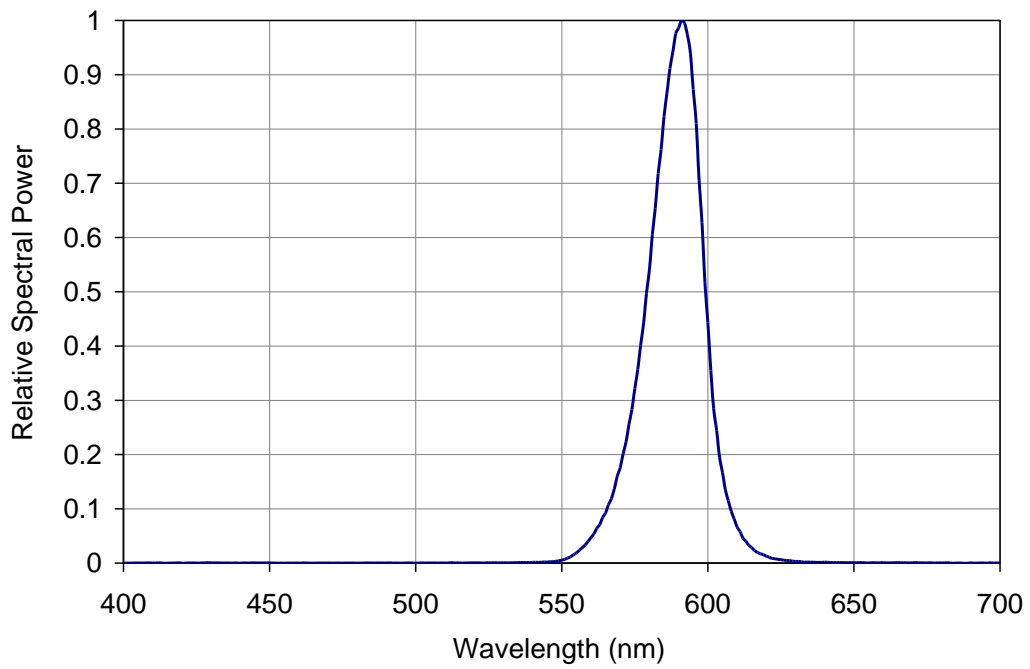

Figure 5: Typical relative spectral power vs. wavelength @ T_C = 25°C

Typical Dominant Wavelength Shift over Case Temperature

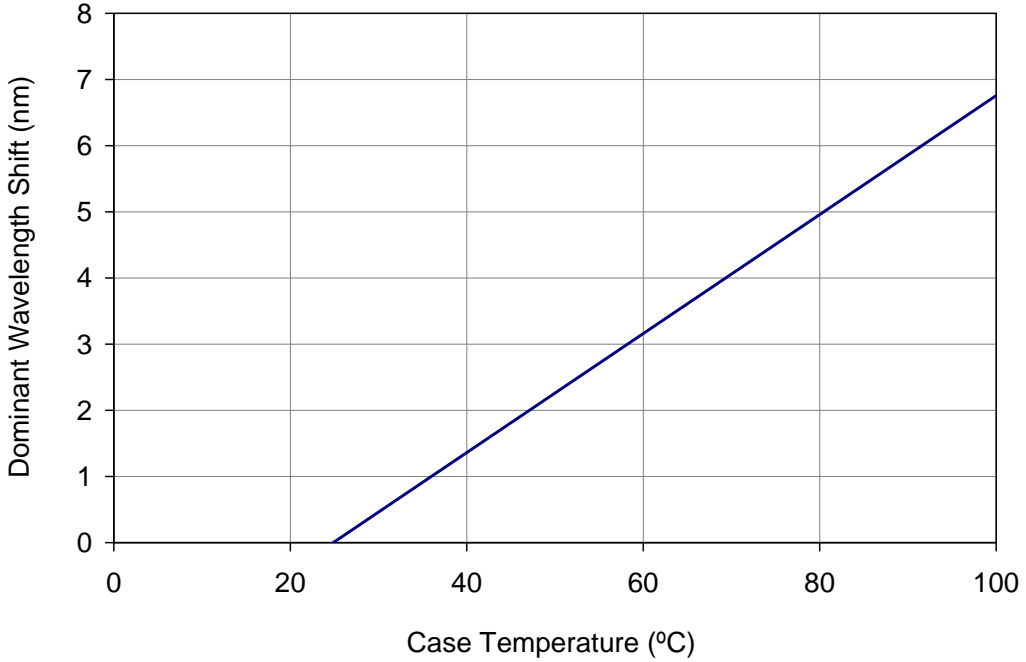

Figure 6: Typical dominant wavelength shift vs. case temperature

Typical Relative Light Output over Current

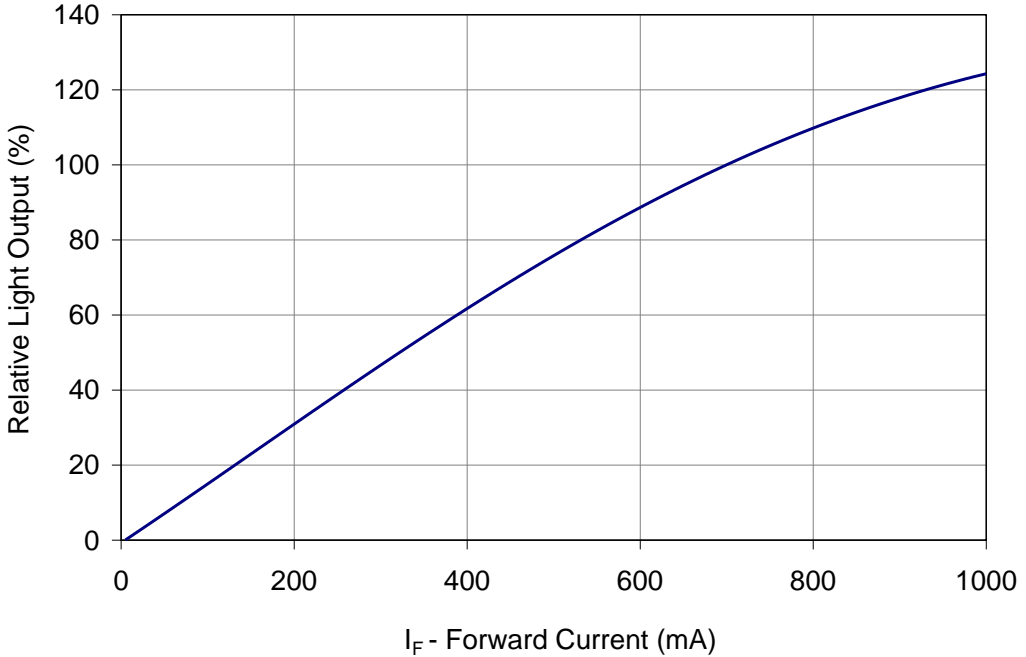

Figure 7: Typical relative light output vs. forward current @ T_C = 25°C

Typical Relative Light Output over Case Temperature

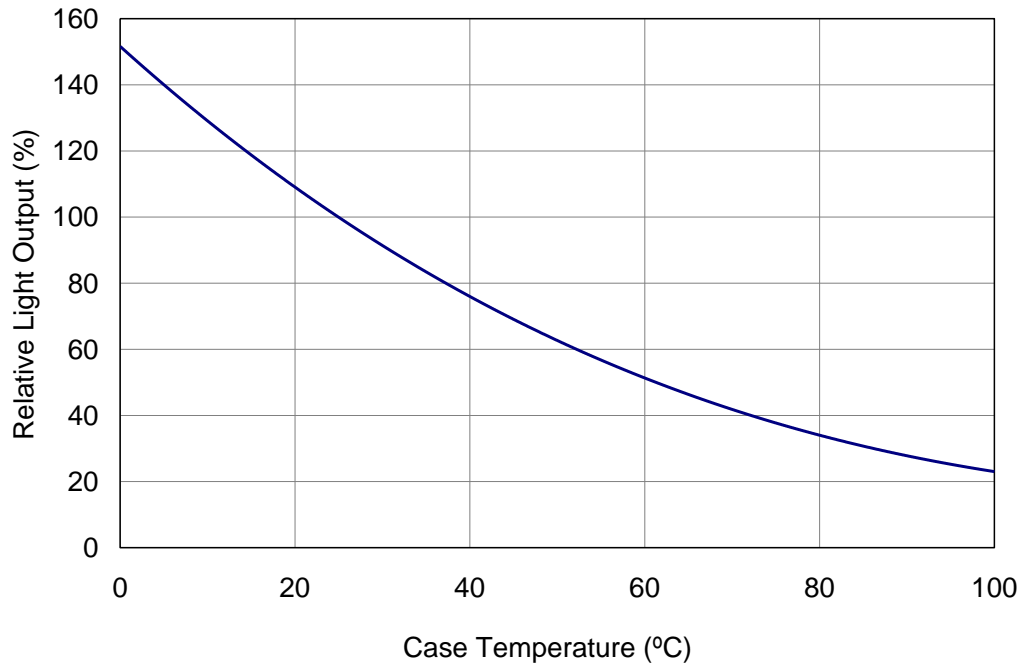

Figure 8: Typical relative light output vs. case temperature

Typical Forward Current Characteristics

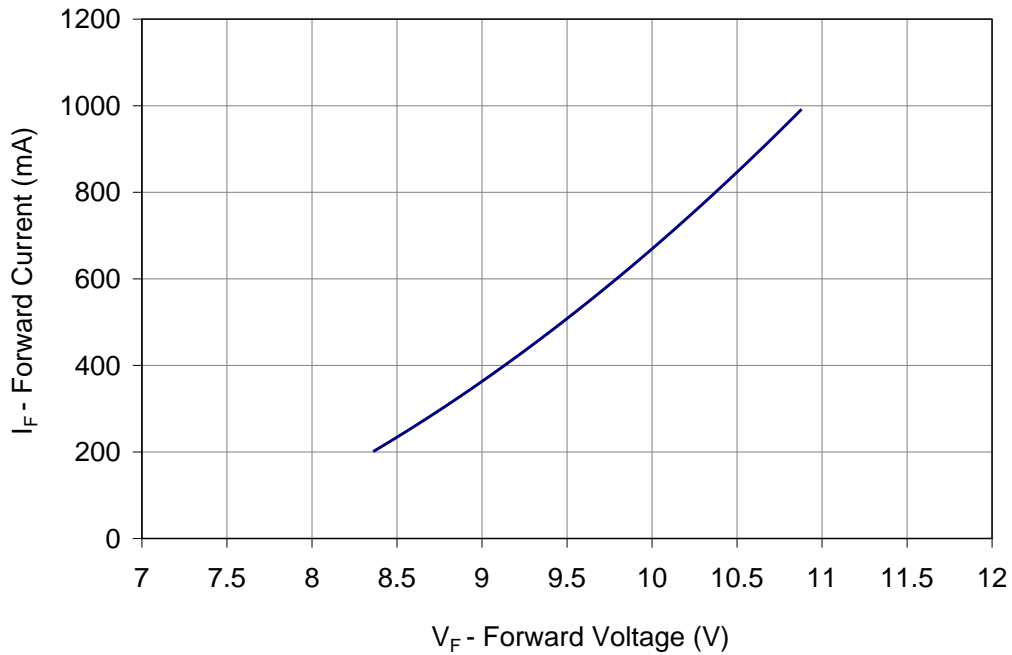

Figure 9: Typical forward current vs. forward voltage @ T_C = 25°C

Note for Figure 9:

- 1. Forward Voltage curve assumes that all four LED dies are connected in series.

Current De-rating

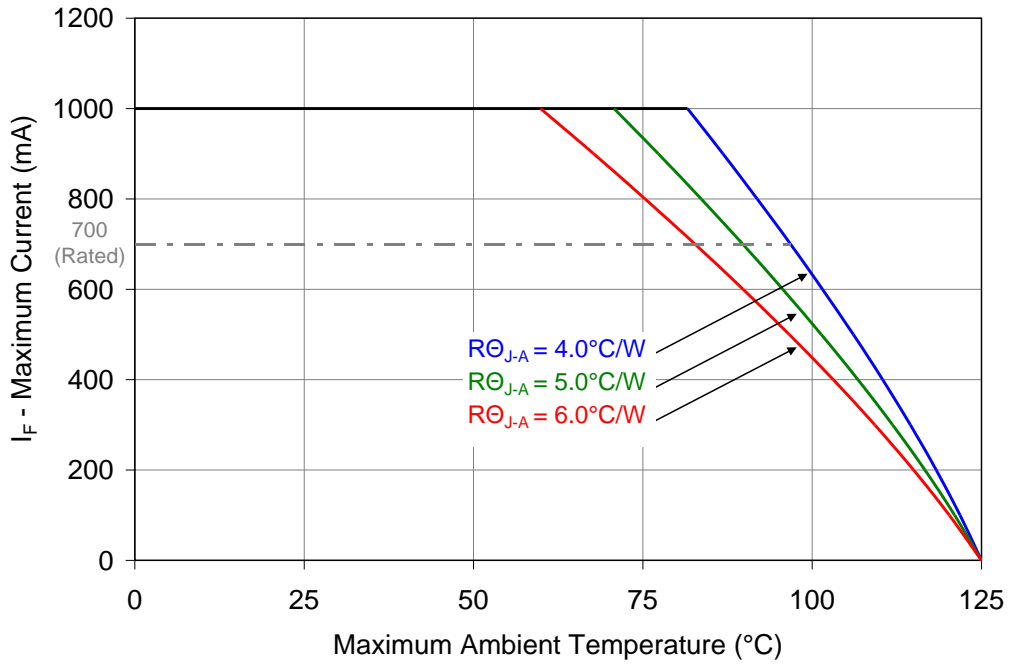

Figure 10: Maximum forward current vs. ambient temperature based on T_{J(MAX)} = 125°C

Notes for Figure 10:

1. Maximum current assumes that all four LED dies are operating concurrently at the same current.
2. R_{Θ_{J-C}} [Junction to Case Thermal Resistance] for the LZ4-00A108 is typically 2.8°C/W.
3. R_{Θ_{J-A}} [Junction to Ambient Thermal Resistance] = R_{Θ_{J-C}} + R_{Θ_{C-A}} [Case to Ambient Thermal Resistance].

Emitter Tape and Reel Specifications (mm)

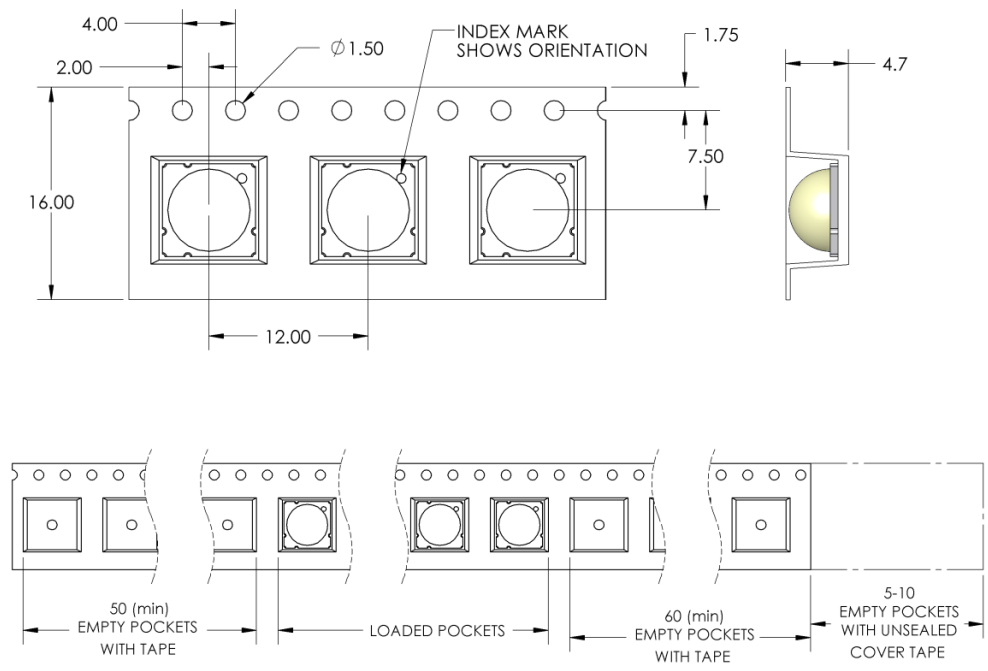

Figure 11: Emitter carrier tape specifications (mm)

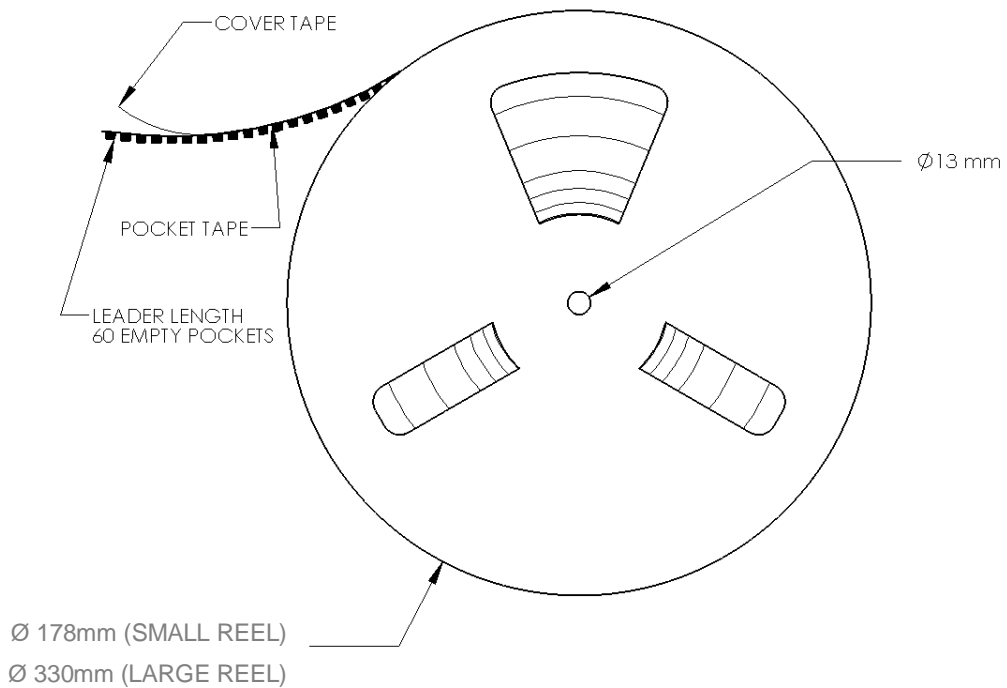

Figure 12: Emitter reel specifications (mm)

Notes for Figure 12:

1. Small reel quantity: up to 250 emitters
2. Large reel quantity: 250-1200 emitters.
3. Single flux bin and single wavelength bin per reel.

LZ4 MCPCB Option

Part number	Type of MCPCB	Dimension (mm)	Emitter + MCPCB Thermal Resistance (°C/W)	Typical V _f (V)	Typical I _f (mA)
LZ4-4xxxxx	1-channel	19.9	2.8 + 1.1 = 3.9	9.0	700

LZ4-4xxxxx

1 channel, Standard Star MCPCB (1x4) Dimensions (mm)

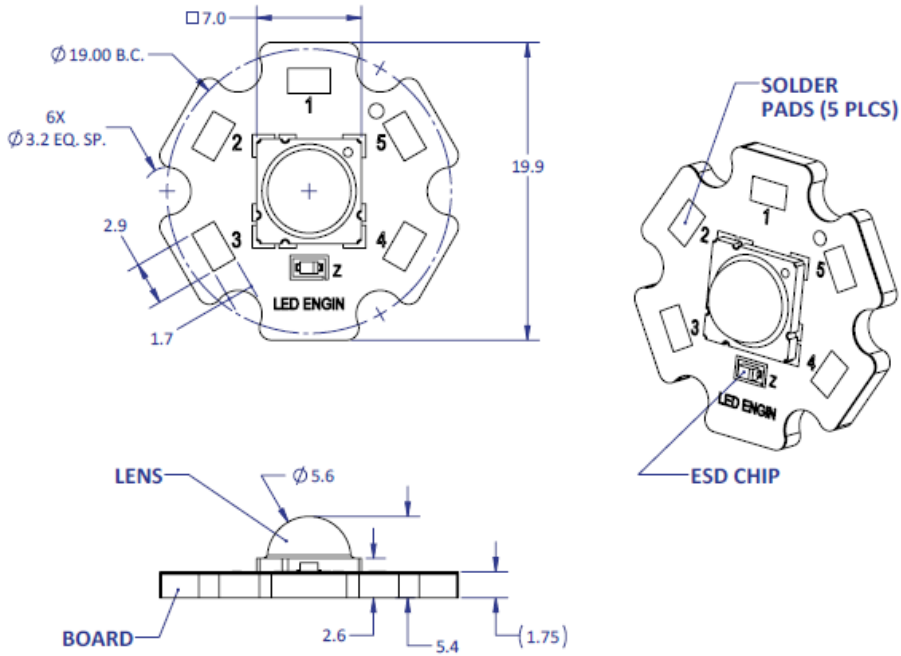

Notes:

1. Unless otherwise noted, the tolerance = ± 0.2 mm.
2. Slots in MCPCB are for M3 or #4-40 mounting screws.
3. LED Engin recommends plastic washers to electrically insulate screws from solder pads and electrical traces.
4. LED Engin recommends thermal interface material when attaching the MCPCB to a heatsink
5. The thermal resistance of the MCPCB is: $RO_{C-B} 1.1^{\circ}C/W$

Components used

MCPCB: HT04503 (Bergquist)
 ESD chips: BZX585-C30 (NXP, for 4 LED dies in series)

Pad layout			
Ch.	MCPCB Pad	String/die	Function
1	1, 2, 3	1/ABCD	Cathode -
	4, 5		Anode +

Application Guidelines

MCPCB Assembly Recommendations

A good thermal design requires an efficient heat transfer from the MCPCB to the heat sink. In order to minimize air gaps in between the MCPCB and the heat sink, it is common practice to use thermal interface materials such as thermal pastes, thermal pads, phase change materials and thermal epoxies. Each material has its pros and cons depending on the design. Thermal interface materials are most efficient when the mating surfaces of the MCPCB and the heat sink are flat and smooth. Rough and uneven surfaces may cause gaps with higher thermal resistances, increasing the overall thermal resistance of this interface. It is critical that the thermal resistance of the interface is low, allowing for an efficient heat transfer to the heat sink and keeping MCPCB temperatures low. When optimizing the thermal performance, attention must also be paid to the amount of stress that is applied on the MCPCB. Too much stress can cause the ceramic emitter to crack. To relax some of the stress, it is advisable to use plastic washers between the screw head and the MCPCB and to follow the torque range listed below. For applications where the heat sink temperature can be above 50°C, it is recommended to use high temperature and rigid plastic washers, such as polycarbonate or glass-filled nylon.

LED Engin recommends the use of the following thermal interface materials:

- Bergquist's Gap Pad 5000S35, 0.020in thick
 - Part Number: Gap Pad® 5000S35 0.020in/0.508mm
 - Thickness: 0.020in/0.508mm
 - Thermal conductivity: 5 W/m-K
 - Continuous use max temperature: 200°C
 - Using M3 Screw (or #4 screw), with polycarbonate or glass-filled nylon washer (#4) the recommended torque range is: 20 to 25 oz-in (1.25 to 1.56 lbf-in or 0.14 to 0.18 N-m)

- 3M's Acrylic Interface Pad 5590H
 - Part number: 5590H @ 0.5mm
 - Thickness: 0.020in/0.508mm
 - Thermal conductivity: 3 W/m-K
 - Continuous use max temperature: 100°C
 - Using M3 Screw (or #4 screw), with polycarbonate or glass-filled nylon washer (#4) the recommended torque range is: 20 to 25 oz-in (1.25 to 1.56 lbf-in or 0.14 to 0.18 N-m)

Mechanical Mounting Considerations

The mounting of MCPCB assembly is a critical process step. Excessive mechanical stress build up in the MCPCB can cause the MCPCB to warp which can lead to emitter substrate cracking and subsequent cracking of the LED dies

LED Engin recommends the following steps to avoid mechanical stress build up in the MCPCB:

- Inspect MCPCB and heat sink for flatness and smoothness.
- Select appropriate torque for mounting screws. Screw torque depends on the MCPCB mounting method (thermal interface materials, screws, and washer).
- Always use three M3 or #4-40 screws with #4 washers.
- When fastening the three screws, it is recommended to tighten the screws in multiple small steps. This method avoids building stress by tilting the MCPCB when one screw is tightened in a single step.
- Always use plastic washers in combinations with the three screws. This avoids high point contact stress on the screw head to MCPCB interface, in case the screw is not seated perpendicular.
- In designs with non-tapped holes using self-tapping screws, it is common practice to follow a method of three turns tapping a hole clockwise, followed by half a turn anti-clockwise, until the appropriate torque is reached.

Wire Soldering

- To ease soldering wire to MCPCB process, it is advised to preheat the MCPCB on a hot plate of 125-150°C. Subsequently, apply the solder and additional heat from the solder iron will initiate a good solder reflow. It is recommended to use a solder iron of more than 60W.
- It is advised to use lead-free, no-clean solder. For example: SN-96.5 AG-3.0 CU 0.5 #58/275 from Kester (pn: 24-7068-7601)

LZ4-00A108

About LED Engin

LED Engin, an OSRAM brand based in California's Silicon Valley, develops, manufactures, and sells advanced LED emitters, optics and light engines to create uncompromised lighting experiences for a wide range of entertainment, architectural, general lighting and specialty applications. LuxiGen™ multi-die emitter and secondary lens combinations reliably deliver industry-leading flux density, upwards of 5000 quality lumens to a target, in a wide spectrum of colors including whites, tunable whites, multi-color and UV LEDs in a unique patented compact ceramic package. Our LuxiTune™ series of tunable white lighting modules leverage our LuxiGen emitters and lenses to deliver quality, control, freedom and high density tunable white light solutions for a broad range of new recessed and downlighting applications. The small size, yet remarkably powerful beam output and superior in-source color mixing, allows for a previously unobtainable freedom of design wherever high-flux density, directional light is required. LED Engin is committed to providing products that conserve natural resources and reduce greenhouse emissions; and reserves the right to make changes to improve performance without notice.

For more information, please contact LEDE-Sales@osram.com or +1 408 922-7200.

LED Engin office:
651 River Oaks Parkway
San Jose, CA 95134
USA
408 922-7200
LEDE-Sales@osram.com
www.osram.us/ledengin

Our Brand

LED ENGIN



OSRAM