

## TRUCKSTAR® LED

H7-LED|24V  
64215DWTS

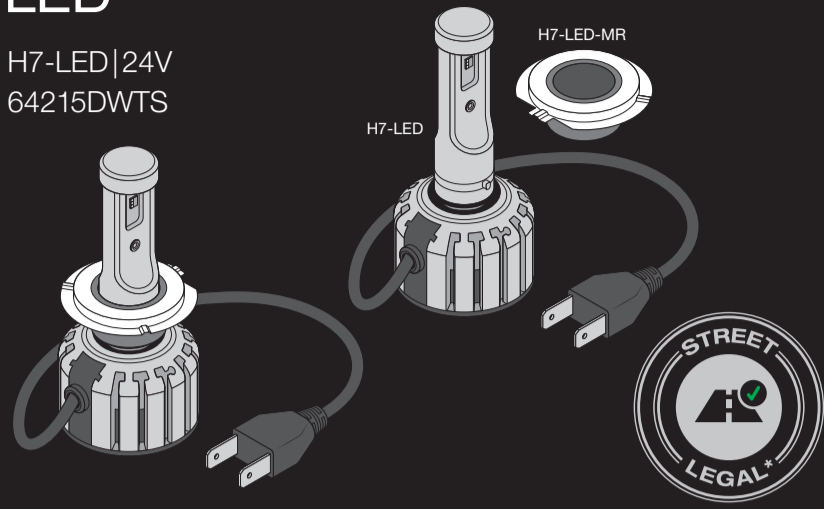

\* Applies only to vehicle models and light functions on the current compatibility list and in the respective country. For more details see [www.osram.com/ts-led](http://www.osram.com/ts-led)

## TRUCKSTAR® LED

H7-LED|24V  
64215DWTS

<http://www.osram.com/am-installation>

For questions regarding maintenance or technical problems, please contact OSRAM customer service via [automotive-service@osram.com](mailto:automotive-service@osram.com)



OSRAM Prosperity Co. Ltd  
Room 4007-4009 Office Tower  
Convention Plaza  
1 Harbour Road  
Wanchai, Hong Kong

[www.osram.com/am-guarantee](http://www.osram.com/am-guarantee)

C15122315  
G15128949  
12.02.24

OSRAM GmbH  
Nonnendammallee 44  
13629 Berlin  
Germany  
[www.osram.com](http://www.osram.com)

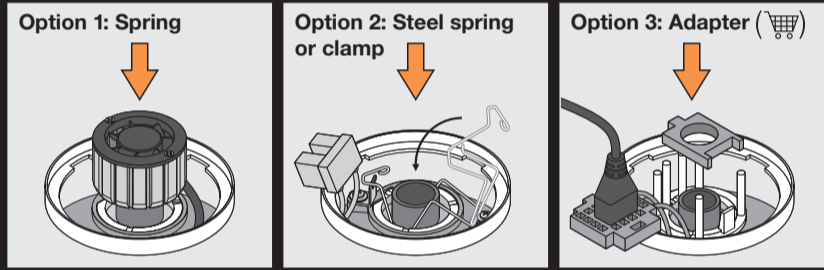
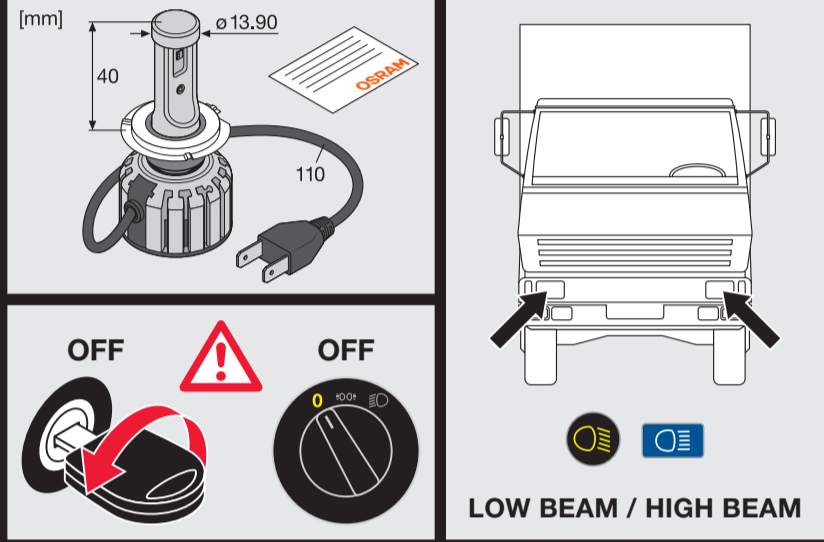

### Option 1: Spring

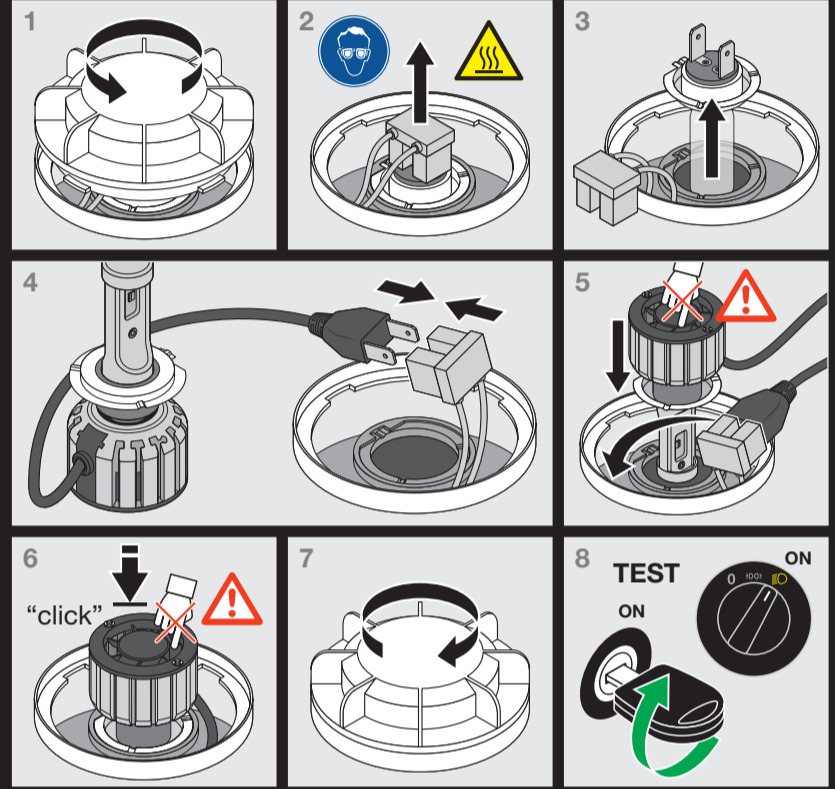

### Option 2: Steel spring or clamp

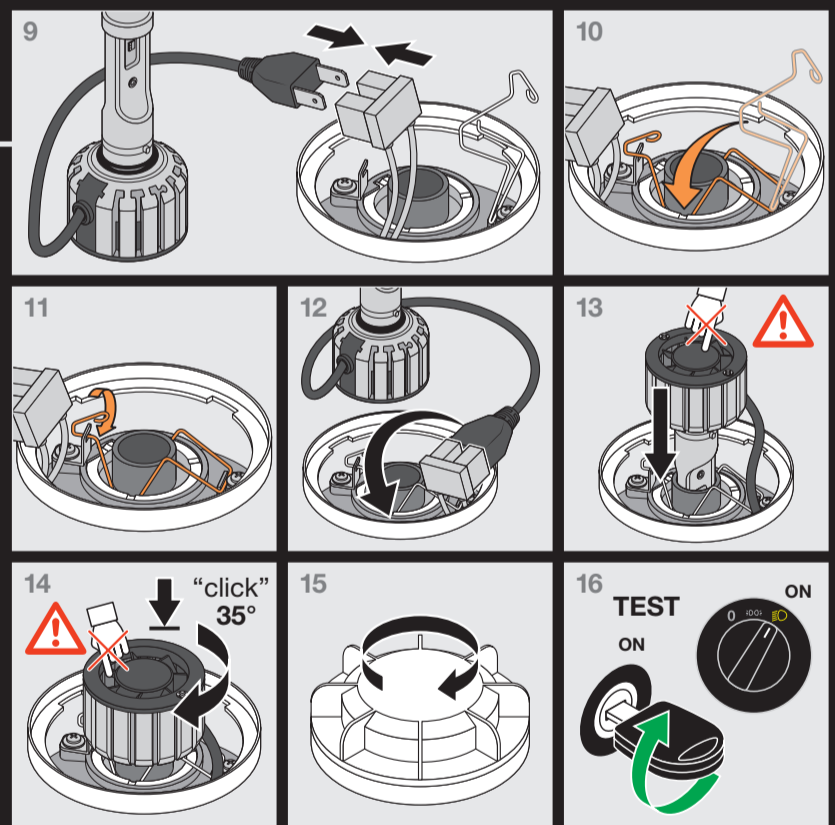
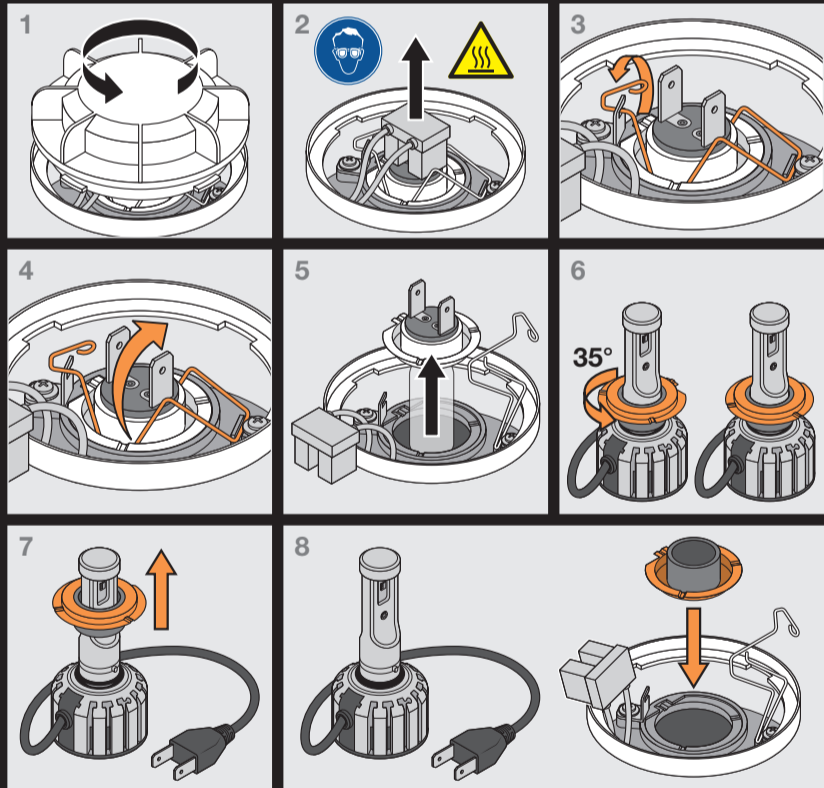

### Option 3: Adapter

Refer to the specific installation instructions of the adapter for detailed information.<sup>10)</sup>

Vehicle	Adapter
Vehicle A	64210DA**
Vehicle B	-
...	-
...	-

